

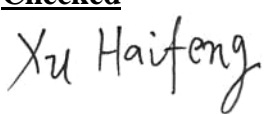

# THERMAL PRINT HEAD

## TX104

**SHEC** SHANDONG HUALING ELECTRONICS CO., LTD.

#159, Torch Road, Hi-Tech. IDZ  
Weihai Shandong, China  
Tel: 86-631-5698013  
Fax: 86-631-5685493  
E-mail: SALES@SHECL.CN

REVISION					<u>Approved</u>
Rev	Description	Date	Approved	Drawn	
A	-----	06-1-9	S.Hosokawa	JM.Liu	
B	B1 The Run length changed, was 100Km(P3)	08-01-21	J. Katagiri	Jianghua	
					<u>Checked</u> 
					<u>Drawn</u> 

### 1. Description

This specification is applied to TX104 thermal print head.

### 2. Scope

The TX104 is a thermal print head which has heat elements which produce 832 dots with 8 dots/mm by means of a high density thick film process. It also includes C-MOS ICs; Which operate as 832 bits shift-registers, latches and switching transistors to drive heat elements.

### 3. Outline

Item	Specification	Note
Dimension	Fig.5	
Schematic diagram	Fig.3	
Pin assignment	Table.3	
Print width	104 mm	
Number of heaters	832 dots	
Heater resolution	8 dots/mm	
Heater pitch	0.125 mm	
Printed dot dimension	0.11mm×0.13 mm	Nominal
Heater resistance	$\bar{R} = 700 \Omega \pm 3 \%$	
Specifications for driver ICs	Table.2	
Number of driver ICs	64bits × 13	
Number of data inputs	1 serial input	
Number of strobes	4	
Logic power supply	5 V × 65mA	at 5 MHz
Specification for Thermistor	$R_{25} = 30K \Omega \pm 5\%, B = 3,950K \pm 3\%$	Table. 1

### 4. Maximum ratings

Parameter	Symbol	Specification	Note
Heater energy consumption	Eomax	0.28 mJ/dot	0.83 ms/line
		0.18 mJ/dot	0.5 ms/line
Head voltage	VH	25.2 V	Between Connectors
Logic voltage	Vdd	Vdd=+5V±0.5V	
Environment temperature	Ta	+5 ° C ~ +50 ° C	Operating
		- 40 ° C ~ +80 ° C	Non-operating
Environment humidity		10 ~ 90%RH	Non-condensing
Maximum operating temperature	Ts	65 ° C 30min. MAX	
		Detected temperature of Thermistor shall not exceed 65 ° C.	Head temperature shall not exceed 70 ° C.

**5. Standard printing conditions**

Parameter	Symbol	Recommended operating conditions		Note	
Speed		0.5 ms/line	0.83 ms/line		
		10 inch/sec	6 inch/sec		
Heater power consumption	Po	0.74 W/dot		$\bar{R} = 700 \Omega$	
Heat voltage	VH	24 V		Connectors	
Heater energy consumption	Eo (ts)	5°C	0.16 mJ/dot (0.22 ms)	0.2 mJ/dot (0.27 ms)	$\bar{R} = 700 \Omega$ (Note 1)
		25°C	0.14 mJ/dot (0.19 ms)	0.18 mJ/dot (0.24 ms)	
		40°C	0.12 mJ/dot (0.16 ms)	0.16 mJ/dot (0.22 ms)	
Supply current	Io	32.5 mA/dot		$\bar{R} = 700 \Omega$	
Timing chart		Fig. 2			
Platen pressure		14.3~ 19.1 N / TPH			
Platen hardness		30~40deg			
Platen diameter		Φ14 Max.			
Scanning resolution		8 line/mm			
Thermal paper		F24OAC / F220-VP MITSUBISHI PAPER MILL CO., LTD.			
Optical density		1.1 OD Min.		(Note 2)	

(Note 1) Supply energy is defined by the following formula.

$$E_o = I_o^2 \bar{R} t_s = \frac{(VH - V_{com})^2 \cdot \bar{R} \cdot t_s}{(\bar{R} + R_{ic})^2}$$

- $R_{ic} = 23 \Omega$  : Driver IC "ON" resistance
- $t_s$  : Strobe printing pulse width
- $VH$  : Heat voltage
- $\bar{R}$  : Heater average resistance
- $V_{com} = 0.5V$  : Common electrode voltage drop

(Note 2) Printed optical density is measured at 10mm intervals after the starting point. Printed optical density is measured by a RD-914 reflector optical density meter or equivalent .

**6. Life expectancy**

**6.1** The life expectancy under 12.5% printing duty of less at 25° C is defined by the following whichever earlier comes.

Item	Specification	Note
Number of pulses	$1 \times 10^8$ pulses	
Run length	150 Km <span style="border: 1px solid black; padding: 0 2px;">B1</span>	

**6.2** Under 10% humidity, the platen roller which is protected by a rubber insulator, will operate under test conditions with no paper for a maximum of 3Km, before the heat element fails.

## 7. Warning during use

### 7.1 Strobe signal

During head power supply ON/OFF sequence strobes should be kept "disable".

### 7.2 Stability of IC operation

Care should be taken for stable operation of driver ICs as indicated bellow. (Fig.1)

(1) If the voltage including surge exceeds maximum rating of driver IC, the TPH may burn out by latch-up. Care should be taken especially when head current changes by strobes or at the ON/OFF sequence. The voltage shall be kept within the following voltage.

VH : 0V ~ +28V

Vdd : 0V ~ +6.5V

Other signals : GND -0V ~ Vdd+0.3V

**7.3** The heater and driver ICs are electrostatically sensitive. Care should be taken not to touch connectors with hands or an electrostatically charged object. It is recommended that brushes near the head be provided to discharge electrostatic build up.

**7.4** On the surface near the heater, do not apply any hard material. The abrasion resistant layer is fragile to mechanical impact.

**7.5** Ink dregs adhered to the heater should be wiped off softly with a soft cloth dipped alcohol or detergent. Do not use sandpaper or equivalent.

**7.6** Keep hard particles out of the heater surface. Hard particles may scratch the abrasion resistant layer.

**7.7** Maximum number of heaters for simultaneous is 448.

**7.8** When the printer is on standby, the thermal head (VH) must be switched off.

**Fig. 1 Recommend Connection**

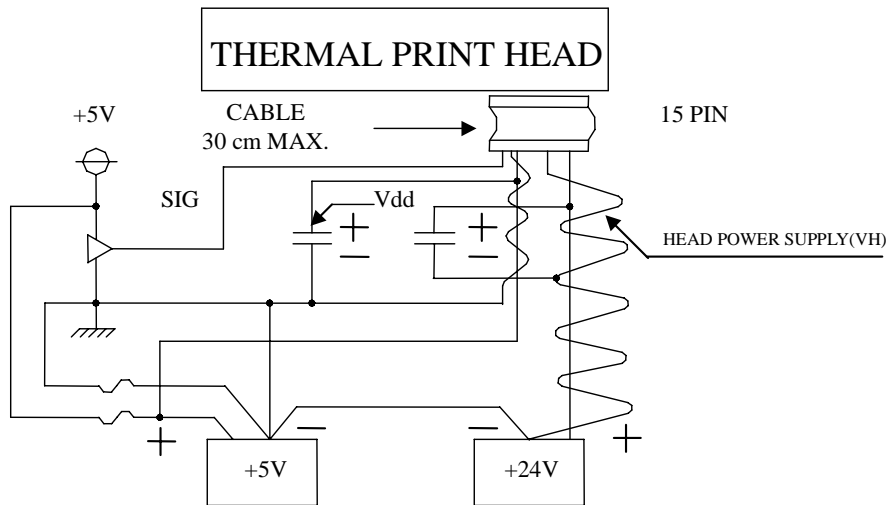

**Table. 1 Thermistor**

$$R_{25} = 30K\Omega \pm 5\%, B_{CONST} = 3950\text{kelvin} \pm 3\%, R = R_{25}e^{B(1/T - 1/T_{25})}$$

Temperature ( ° C )	Thermistor Resistance (R)		
	Min .(KΩ)	Typ. (KΩ)	Max. (KΩ)
-40.0	717	843	989
-35.0	535	623	723
-30.0	405	466	535
-25.0	308	352	400
-20.0	238	269	303
-15.0	185	208	232
-10.0	145	161	178
-5.0	113	124	137
0.0	88.7	96.8	105
5.0	69.9	75.7	81.7
10.0	55.4	59.5	63.8
15.0	44.1	47.1	50.1
20.0	35.4	37.5	39.6
25.0	28.5	30.0	31.5
30.0	22.8	24.2	25.5
35.0	18.3	19.6	20.8
40.0	14.9	15.9	17.1
45.0	12.1	13.1	14.1
50.0	9.92	10.8	11.7
55.0	8.16	8.91	9.7
60.0	6.76	7.41	8.12
65.0	5.62	6.2	6.83
70.0	4.7	5.21	5.77
75.0	3.95	4.4	4.9
80.0	3.34	3.74	4.18

**Table 2 C-MOS Driver IC**

**Table 2.1** Electrical characteristics for driver IC.

Absolute maximum ratings for driver ICs.

Parameter	Symbol	Test conditions	Ratings	Unit
Supply voltage	$V_{dd}$	Surge	0 ~ 6.5	V
	$V_H$	Surge	0 ~ 28	V
Input voltage for logic	$V_{IN}$		0 ~ $V_{dd}+0.5$	V

Recommended operating conditions

Parameter	Symbol	Test conditions	Recommendations			Unit
			Min.	Typ.	Max.	
Supply voltage	$V_{dd}$		4.5	5.0	5.5	V
	$V_H$	Supply voltage for VH	23.5	24.0	24.5	V
Input voltage for logic	$V_{IH}$	(Note 1)	$0.8 \times V_{dd}$		$V_{dd}$	V
	$V_{IL}$		0		$0.2 \times V_{dd}$	V
Clock frequency	$f_{CLK}$	cascade			5	MHz

(Note 1) Recommended driver IC is 74HC244 or equivalent.

**Table 2.2** Electrical characteristics for driver IC.

Parameter	Symbol	Test conditions	Ratings			Unit
			Min.	Typ.	Max.	
Input current	$\overline{LATCH}$	(Note 1) $V_{dd}=5V$ $V_{IH}=5V$			6.5	$\mu A$
	$\overline{STROBE}$				2.0	$\mu A$
	CLOCK				6.5	$\mu A$
	DATA IN				0.5	$\mu A$
	$\overline{LATCH}$	$I_{IL}$ $V_{dd}=5V$ $V_{IL}=0V$	-6.5			$\mu A$
	$\overline{STROBE}$		-220			$\mu A$
	CLOCK		-6.5			$\mu A$
	DATA IN		-0.5			$\mu A$
“L” Output voltage of drivers	$V_{OL}$	$I_{OL}=30mA$		0.7	1.5	V
Leak current of drivers	$I_{LEAK}$	$V_{OH}=28V$			1.0	$\mu A/dot$
Logic supply current	$I_{dd}$	$SI=1/2f_{clk}$ $f_{CLK}=5MHz$		20.8	65	mA

(Note 1) Each  $\overline{STROBE}$  includes pull-up resistance of  $300K\Omega \pm 50\%$  per IC.

**Table 2.3** Switching characteristics for driver ICs.

Parameter	Symbol	Test conditions	Ratings			Unit
			Min.	Typ.	Max.	
Clock frequency	$f_{MAX}$	cascade			5	MHz
Clock pulse width	$tw(T)$		70			ns
Data setup time	$tsu(D)$		40			ns
Data hold time	$th(D)$		40			ns
Latch setup time	$tsu(LA)$		100			ns
Latch pulse width	$tw(LA)$		100			ns
Strobe to driver Output delay time	$tdDO$				10.5	$\mu s$

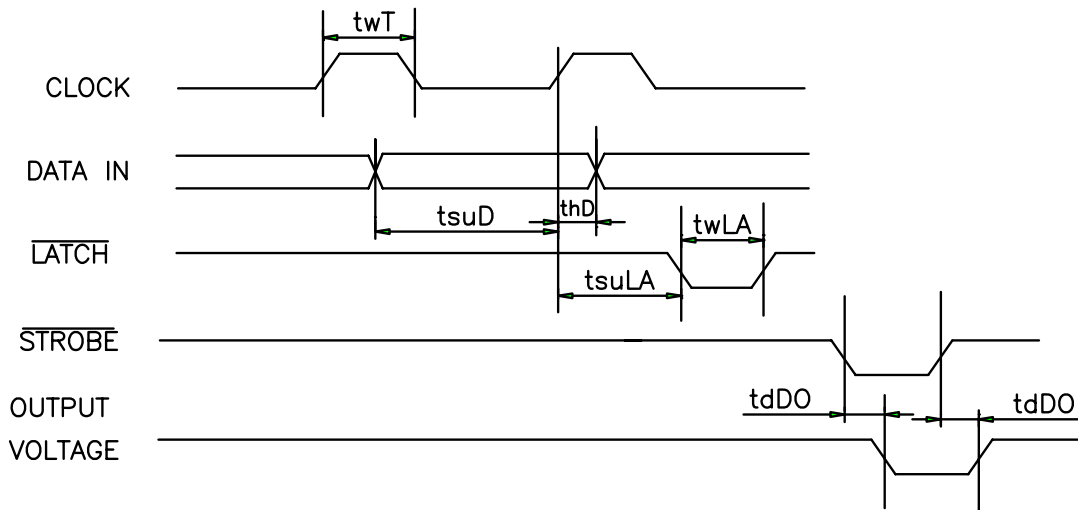

**Fig. 2** Thermal Print Head (TX104) Timing Chart

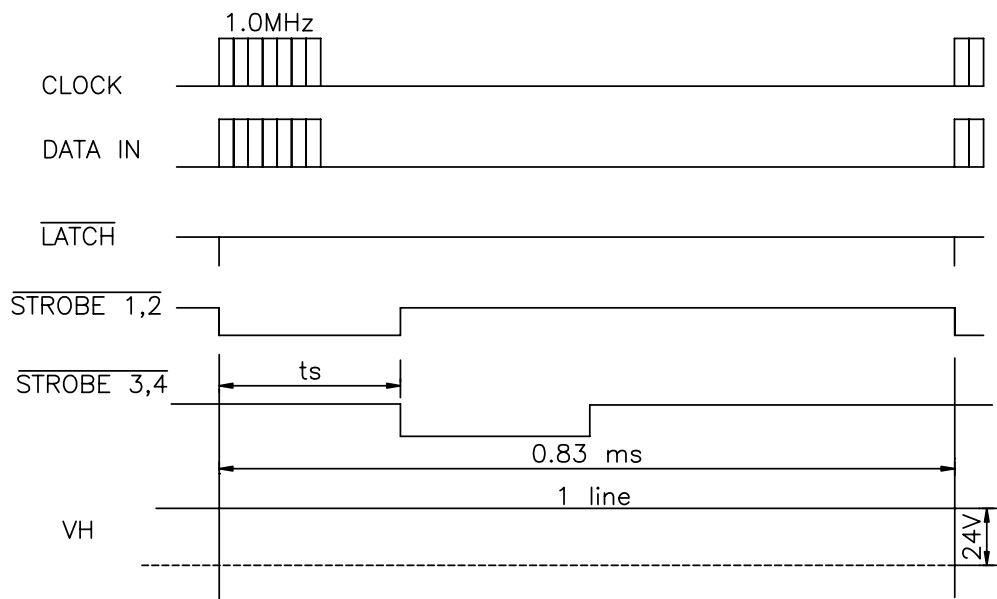

**Fig. 3 Schematic Diagram**

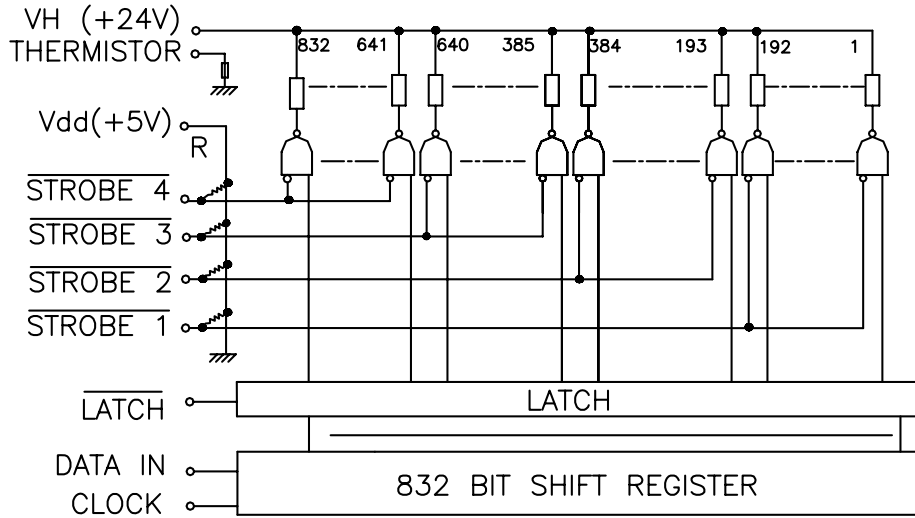

**Fig. 4 Cross Section**

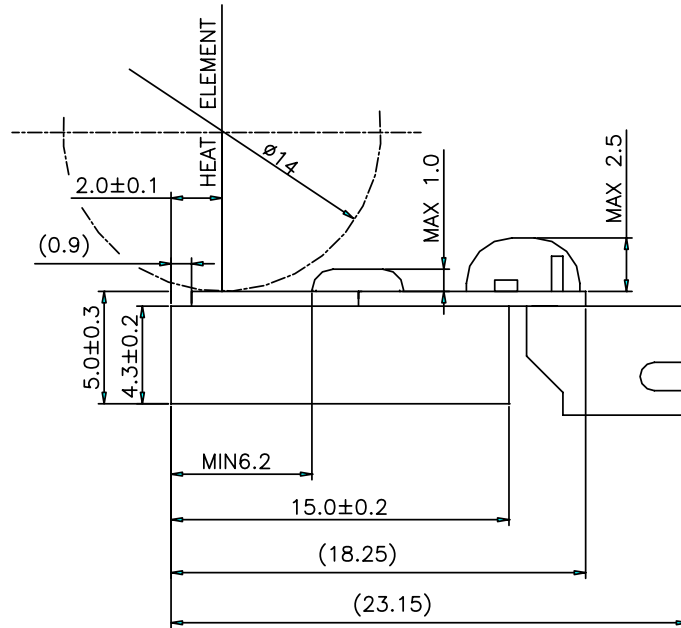

**Table. 3 Pin assignment**

Connector : S15B-PH-K-S-2.2(LF)(SN)

PIN	NAME	PIN	NAME
1	VH	9	<u>STROBE1</u>
2	VH	10	<u>STROBE2</u>
3	VH	11	<u>STROBE3</u>
4	GND	12	<u>STROBE4</u>
5	GND	13	<u>CLOCK</u>
6	GND	14	<u>LATCH</u>
7	Vdd	15	DATA IN
8	THERMISTOR		

**Fig. 5 Dimension**

