

THERMAL PRINT HEAD

T80

SHEC SHANDONG HUALING ELECTRONICS CO., LTD.

#159, Torch Road, Hi-Tech. IDZ

Weihai Shandong, China

Tel: 86-631-5698012

Fax: 86-631-5685493

E-mail: shec@163169.net

REVISION					<u>Approved</u>
Rev	Description	Date	Approved	Drawn	
A	-----	04-3-11	S.Hosokawa	HX.Cong	<i>S. Hosokawa</i>
B	B1 Connector type changed ,was S15B-PH-K-S-2.2 B2 Add note 3	06-4-11	S.Hosokawa	HF.XU	
					<u>Checked</u> <i>S. Hosokawa</i>
					<u>Drawn</u> <i>Xu Haifeng</i>

1. Description

This specification is applied to T80 thermal print head.

2. Scope

The T80 is a thermal print head which has heat elements which produce 640 dots with 8 dots/mm by means of a high density thick film process. It also includes C-MOS ICs; Which operate as 640 bits shift-registers, latches and switching transistors to drive heat elements.

3. Outline

Item	Specification	Note
Dimension	Fig.5	
Schematic diagram	Fig.3	
Pin assignment	Table.3	
Print width	80 mm	
Number of heaters	640 dots	
Heater resolution	8 dots/mm	
Heater pitch	0.125 mm	
Printed dot dimension	0.11mm×0.13 mm	Nominal
Heater resistance	$\bar{R}=700\Omega \pm 3\%$	
Specifications for driver ICs	Table.2	
Number of driver ICs	64bits × 10	
Number of data inputs	1 serial input	
Number of strobes	4	
Logic power supply	5 V × 50 mA	at 5 MHz
Specification for Thermistor	$R_{25}=30K\Omega \pm 5\%, B=3,950K \pm 3\%$	Table. 1

4. Maximum ratings

Parameter	Symbol	Specification	Note
Heater energy consumption	Eomax	0.28 mJ/dot	0.83 ms/line
		0.18 mJ/dot	0.5 ms/line
Head voltage	VH	25.2 V	Between Connectors
Logic voltage	Vdd	Vdd=+5V±0.25V	
Environment temperature	Ta	+5 ° C ~ +50 ° C	Operating
		- 40 ° C ~ +80 ° C	Non-operating
Environment humidity		10 ~ 90%RH	Non-condensing
Maximum operating temperature	Ts	65 ° C 30min. MAX	
		Detected temperature of Thermistor shall not exceed 65 ° C.	Head temperature shall not exceed 70 ° C.

5. Standard printing conditions

Parameter	Symbol	Recommended operating conditions		Note	
Speed		0.5 ms/line	0.83 ms/line		
		10 inch/sec	6 inch/sec		
Heater power consumption	Po	0.74 W/dot		$\bar{R} = 700 \Omega$	
Heat voltage	VH	24 V		Connectors	
Heater energy consumption	Eo (ts)	5°C	0.16mJ/dot (0.22 ms)	0.2mJ/dot (0.27 ms)	$\bar{R} = 700 \Omega$ (Note 1)
		25°C	0.14mJ/dot (0.19 ms)	0.18mJ/dot (0.24 ms)	
		40°C	0.12mJ/dot (0.16 ms)	0.16mJ/dot (0.22 ms)	
Supply current	Io	32.5 mA/dot		$\bar{R} = 700 \Omega$	
Timing chart		Fig. 2			
Platen pressure		11.2 ~ 14.9 N / TPH			
Platen hardness		30~40deg			
Platen diameter		Φ14 Max.			
Scanning resolution		8 line/mm			
Thermal paper		F24OAC / F220-VP MITSUBISHI PAPER MILL CO., LTD.			
Optical density		1.1 OD Min.		(Note 2)	

(Note 1) Supply energy is defined by the following formula.

$$E_o = I_o^2 \bar{R} t_s = \frac{(VH - V_{com})^2 \cdot \bar{R} \cdot t_s}{(\bar{R} + R_{ic})^2}$$

- $R_{ic} = 23 \Omega$: Driver IC "ON" resistance
- t_s : Strobe printing pulse width
- VH : Heat voltage
- \bar{R} : Heater average resistance
- $V_{com} = 0.5V$: Common electrode voltage drop

(Note 2) Printed optical density is measured at 10mm intervals after the starting point. Printed optical density is measured by a RD-914 reflector optical density meter or equivalent .

6. Life expectancy

6.1 The life expectancy under 12.5% printing duty of less at 25° C is defined by the following whichever earlier comes.

Item	Specification	Note
Number of pulses	1×10^8 pulses	
Run length	100 Km	

6.2 Under 10% humidity, the platen roller which is protected by a rubber insulator, will operate under test conditions with no paper for a maximum of 3Km, before the heat element fails.

7. Warning during use

7.1 Strobe signal

During head power supply ON/OFF sequence strobes should be kept "disable".

7.2 Stability of IC operation

Care should be taken for stable operation of driver ICs as indicated bellow. (Fig.1)

(1) If the voltage including surge exceeds maximum rating of driver IC, the TPH may burn out by latch-up. Care should be taken especially when head current changes by strobes or at the ON/OFF sequence. The voltage shall be kept within the following voltage.

VH : 0V ~ +28V

Vdd : 0V ~ +6.5V

Other signals : GND -0V ~ Vdd+0.3V

7.3 The heater and driver ICs are electrostatically sensitive. Care should be taken not to touch connectors with hands or an electrostatically charged object. It is recommended that brushes near the head be provided to discharge electrostatic build up.

7.4 On the surface near the heater, do not apply any hard material. The abrasion resistant layer is fragile to mechanical impact.

7.5 Ink dregs adhered to the heater should be wiped off softly with a soft cloth dipped alcohol or detergent. Do not use sandpaper or equivalent.

7.6 Keep hard particles out of the heater surface. Hard particles may scratch the abrasion resistant layer.

7.7 Maximum number of heaters for simultaneous is 320.

7.8 When the printer is on standby, the thermal head (VH) must be switched off.

Fig. 1 Recommend Connection

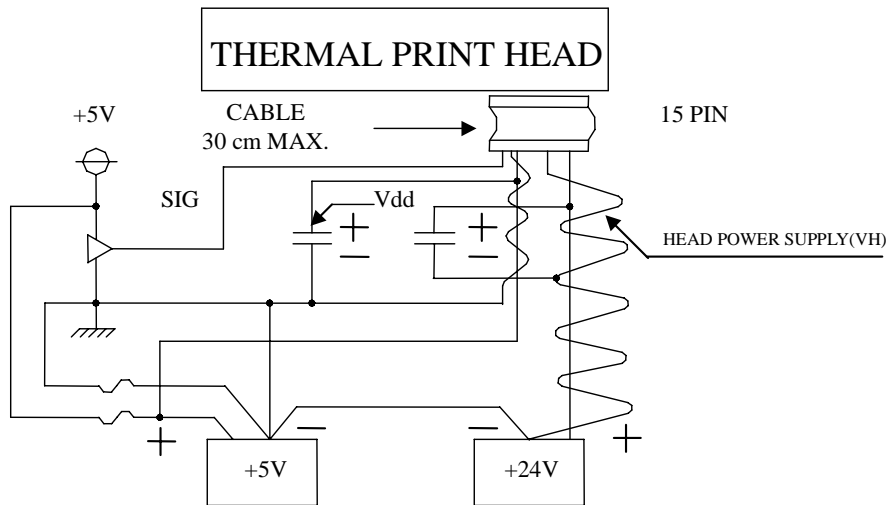

Table. 1 Thermistor

$$R_{25} = 30K\Omega \pm 5\%, B_{CONST} = 3950\text{kelvin} \pm 3\%, R = R_{25}e^{B(1/T - 1/T_{25})}$$

Temperature (° C)	Thermistor Resistance (R)		
	Min .(KΩ)	Typ. (KΩ)	Max. (KΩ)
-40.0	717	843	989
-35.0	535	623	723
-30.0	405	466	535
-25.0	308	352	400
-20.0	238	269	303
-15.0	185	208	232
-10.0	145	161	178
-5.0	113	124	137
0.0	88.7	96.8	105
5.0	69.9	75.7	81.7
10.0	55.4	59.5	63.8
15.0	44.1	47.1	50.1
20.0	35.4	37.5	39.6
25.0	28.5	30.0	31.5
30.0	22.8	24.2	25.5
35.0	18.3	19.6	20.8
40.0	14.9	15.9	17.1
45.0	12.1	13.1	14.1
50.0	9.92	10.8	11.7
55.0	8.16	8.91	9.7
60.0	6.76	7.41	8.12
65.0	5.62	6.2	6.83
70.0	4.7	5.21	5.77
75.0	3.95	4.4	4.9
80.0	3.34	3.74	4.18

Table 2 C-MOS Driver IC

Table 2.1 Electrical characteristics for driver IC.

Absolute maximum ratings for driver ICs.

Parameter	Symbol	Test conditions	Ratings	Unit
Supply voltage	V_{dd}	Surge	0 ~ 6.5	V
	V_H	Surge	0 ~ 28	V
Input voltage for logic	V_{IN}		0 ~ $V_{dd}+0.3$	V

Recommended operating conditions

Parameter	Symbol	Test conditions	Recommendations			Unit
			Min.	Typ.	Max.	
Supply voltage	V_{dd}		4.5	5.0	5.2	V
	V_H	Supply voltage for VH	23.5	24.0	24.5	V
Input voltage for logic	V_{IH}	(Note 1)	$0.7 \times V_{dd}$		V_{dd}	V
	V_{IL}		0		$0.3 \times V_{dd}$	V
Clock frequency	f_{CLK}	cascade			5	MHz

(Note 1) Recommended driver IC is 74HC244 or equivalent.

Table 2.2 Electrical characteristics for driver IC.

Parameter	Symbol	Test conditions	Ratings			Unit
			Min.	Typ.	Max.	
Input current	\overline{LATCH}	(Note 1) $V_{dd}=5.0V$ $V_{IH}=5.0V$			5.0	μA
	\overline{STROBE}				1.5	μA
	CLOCK				5.0	μA
	DATA IN				0.5	μA
	\overline{LATCH}	I_{IL} $V_{dd}=5.0V$ $V_{IL}=0V$	-5.0			μA
	\overline{STROBE}		-165			μA
	CLOCK		-5.0			μA
	DATA IN		-0.5			μA
“L” Output voltage of drivers	V_{OL}	$I_{OL}=30mA$		0.7	1.5	V
Leak current of drivers	I_{LEAK}	$V_{OH}=28V$			1.0	$\mu A/dot$
Logic supply current	I_{dd}	$SI=1/2f_{CLK}$ $f_{CLK}=5MHz$		16	50	mA

(Note 1) Each \overline{STROBE} includes pull-up resistance of $300K\Omega \pm 50\%$ per IC.

Table 2.3 Switching characteristics for driver ICs.

Parameter	Symbol	Test conditions	Ratings			Unit
			Min.	Typ.	Max.	
Clock frequency	f_{MAX}				5	MHz
Clock pulse width	tw(T)		70			ns
Data setup time	tsu(D)		40			ns
Data hold time	th(D)		40			ns
Latch setup time	tsu(LA)		100			ns
Latch pulse width	tw(LA)		100			ns
Strobe to driver Output delay time	td(DO)				10.5	μ s

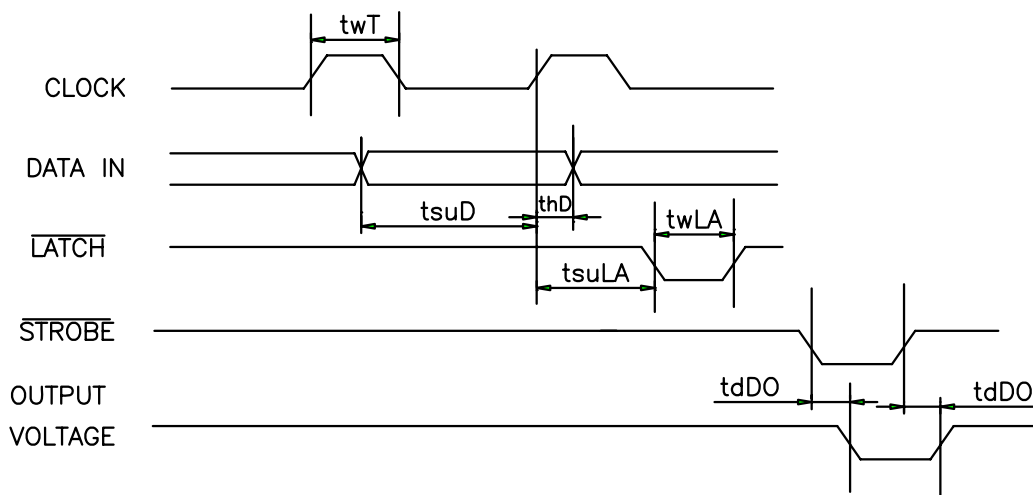

Fig. 2 Thermal Print Head (T80) Timing Chart

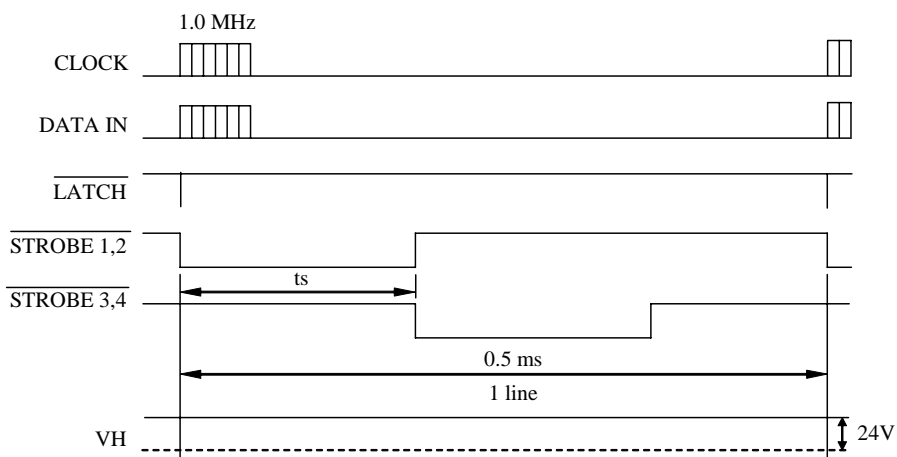

Fig. 3 Schematic Diagram

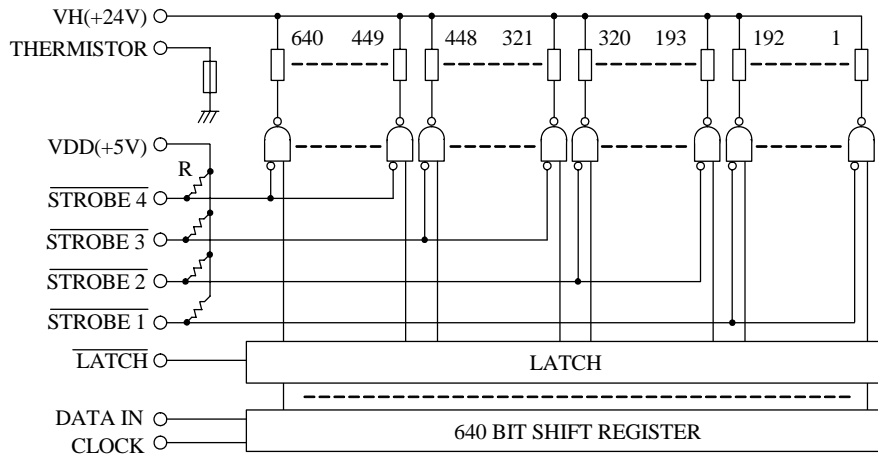

Fig. 4 Cross Section

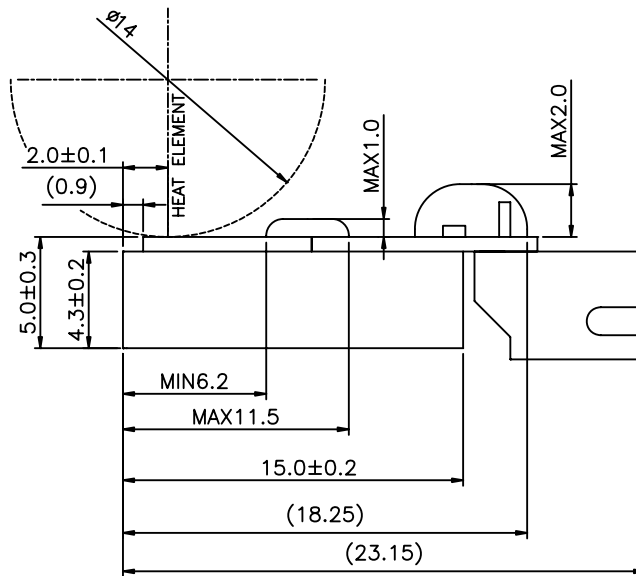

Table. 3 Pin assignment

Connector : S15B-PH-K-S-2.2(LF)(SN) or EQUIVALENT B1

PIN	NAME	PIN	NAME
1	VH	9	$\overline{STROBE1}$
2	VH	10	$\overline{STROBE2}$
3	VH	11	$\overline{STROBE3}$
4	GND	12	$\overline{STROBE4}$
5	GND	13	CLOCK
6	GND	14	\overline{LATCH}
7	Vdd	15	DATA IN
8	THERMISTOR		

Fig. 5 Dimension

