

THERMAL PRINT HEAD

CH56

SHEC SHANDONG HUALING ELECTRONICS CO., LTD.

#159, Torch Road, Hi-Tech. IDZ
Weihai Shandong, China
Tel: 86-631-5698012
Fax: 86-631-5685493
E-mail: SALES@SHECL.CN

| REVISION | | | | | <u>Approved</u> |
|----------|-------------|----------|------------|----------|--------------------|
| Rev | Description | Date | Approved | Drawn | <i>S. Hosokawa</i> |
| A | ----- | 07-07-25 | S.Hosokawa | Jianghua | |
| | | | | | <u>Checked</u> |
| | | | | | <i>Xu Haifeng</i> |
| | | | | | |
| | | | | | <u>Drawn</u> |
| | | | | | <i>Jianghua</i> |
| | | | | | |

1. Description

This specification is applied to CH56 thermal print head.

2. Scope

The CH56 is a thermal print head which has heat elements which produce 448 dots with 8 dots/mm by means of a high density thick film process. It also includes C-MOS ICs; Which operate as 448 bits shift-registers, latches and switching transistors to drive heat elements.

3. Outline

| Item | Specification | Note |
|-------------------------------|---|----------|
| Dimension | Fig.5 | |
| Schematic diagram | Fig.3 | |
| Pin assignment | Table.3 | |
| Print width | 56 mm | |
| Number of heaters | 448 dots | |
| Heater resolution | 8 dots/mm | |
| Heater pitch | 0.125 mm | |
| Printed dot dimension | 0.11mm×0.13 mm | Nominal |
| Heater resistance | $\bar{R} = 700 \Omega \pm 3 \%$ | |
| Specifications for driver ICs | Table.2 | |
| Number of driver ICs | 64bits ×7 | |
| Number of data inputs | 1 serial input | |
| Number of strobos | 3 | |
| Logic power supply | 5 V ×35 mA | at 5 MHz |
| Specification for Thermistor | $R_{25} = 30K \Omega \pm 5\%, B = 3,950K \pm 3\%$ | Table. 1 |

4. Maximum ratings

| Parameter | Symbol | Specification | Note |
|-------------------------------|--------|---|---|
| Heater energy consumption | Eomax | | |
| | | 0.4 mJ/dot | 1.25 ms/line |
| | | 0.5 mJ/dot | 2.5 ms/line |
| Head voltage | VH | 24.5 V | Between Connectors |
| Logic voltage | Vdd | Vdd=+5.5V | |
| Environment temperature | Ta | +5 ° C ~ +50 ° C | Operating |
| | | - 40 ° C ~ +80 ° C | Non-operating |
| Environment humidity | | 10 ~ 90%RH | Non-condensing |
| Maximum operating temperature | Ts | 65 ° C 30min. MAX | |
| | | Detected temperature of Thermistor shall not exceed 65 ° C. | Head temperature shall not exceed 70 ° C. |

5. Standard printing conditions

| Parameter | Symbol | Recommended operating conditions | | Note | |
|---------------------------|---------|---|----------------------|------------------------|---------------------------------|
| Speed | | 1.25 ms/line | 2.5 ms/line | | |
| | | 4 inch/sec | 2 inch/sec | | |
| Heater power consumption | Po | 0.74W/dot | | $\bar{R} = 700 \Omega$ | |
| Heat voltage | VH | 24 V | | Connectors | |
| Heater energy consumption | Eo (ts) | 5°C | 0.19 mJ/dot (0.26ms) | 0.25 mJ/dot (0.34ms) | $\bar{R} = 700 \Omega$ (Note 1) |
| | | 25°C | 0.17 mJ/dot (0.23ms) | 0.23 mJ/dot (0.31ms) | |
| | | 40°C | 0.15 mJ/dot (0.21ms) | 0.21 mJ/dot (0.28ms) | |
| Supply current | Io | 32.5 mA/dot | | $\bar{R} = 700 \Omega$ | |
| Timing chart | | Fig. 2 | | | |
| Platen pressure | | 8.2 ~ 10.9 N / TPH | | | |
| Platen hardness | | 30~40deg | | | |
| Platen diameter | | Φ14 Max. | | | |
| Scanning resolution | | 8 line/mm | | | |
| Thermal paper | | F24OAC / F220-VP MITSUBISHI PAPER MILL CO., LTD. | | | |
| Optical density | | 1.1 OD Min. | | (Note 2) | |

(Note 1) Supply energy is defined by the following formula.

$$E_o = I_o^2 \bar{R} t_s = \frac{(VH - V_{com})^2 \cdot \bar{R} \cdot t_s}{(\bar{R} + R_{ic})^2}$$

- $R_{ic} = 23 \Omega$: Driver IC "ON" resistance
- t_s : Strobe printing pulse width
- VH : Heat voltage
- \bar{R} : Heater average resistance
- $V_{com} = 0.5V$: Common electrode voltage drop

(Note 2) Printed optical density is measured at 10mm intervals after the starting point. Printed optical density is measured by a RD-914 reflector optical density meter or equivalent .

6. Life expectancy

6.1 The life expectancy under 12.5% printing duty of less at 25° C is defined by the following whichever earlier comes.

| Item | Specification | Note |
|------------------|------------------------|------|
| Number of pulses | 1×10^8 pulses | |
| Run length | 100 Km | |

6.2 Under 10% humidity, the platen roller which is protected by a rubber insulator, will operate under test conditions with no paper for a maximum of 3Km, before the heat element fails.

7. Warning during use

7.1 Strobe signal

During head power supply ON/OFF sequence strobes should be kept "disable".

7.2 Stability of IC operation

Care should be taken for stable operation of driver ICs as indicated bellow. (Fig.1)

(1) If the voltage including surge exceeds maximum rating of driver IC, the TPH may burn out by latch-up. Care should be taken especially when head current changes by strobes or at the ON/OFF sequence. The voltage shall be kept within the following voltage.

VH : 0V ~ +28V

Vdd : 0V ~ +6.5V

Other signals : GND -0V ~ Vdd+0.3V

7.3 The heater and driver ICs are electrostatically sensitive. Care should be taken not to touch connectors with hands or an electrostatically charged object. It is recommended that brushes near the head be provided to discharge electrostatic build up.

7.4 On the surface near the heater, do not apply any hard material. The abrasion resistant layer is fragile to mechanical impact.

7.5 Ink dregs adhered to the heater should be wiped off softly with a soft cloth dipped alcohol or detergent. Do not use sandpaper or equivalent.

7.6 Keep hard particles out of the heater surface. Hard particles may scratch the abrasion resistant layer.

7.7 Maximum number of heaters for simultaneous is 192.

7.8 When the printer is on standby, the thermal head (VH) must be switched off.

Fig. 1 Recommend Connection

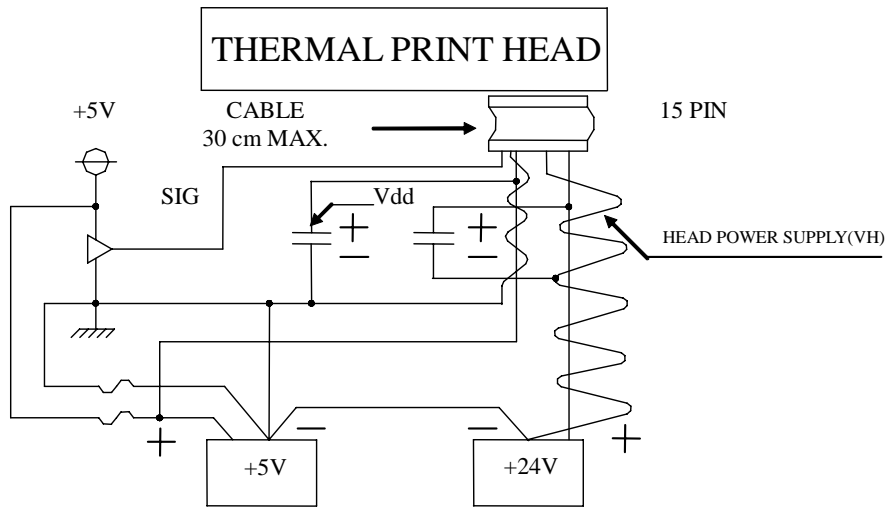

Table. 1 Thermistor

$$R_{25} = 30K\Omega \pm 5\%, B_{CONST} = 3950\text{kelvin} \pm 3\%, R = R_{25}e^{B(1/T - 1/T_{25})}$$

| Temperature (° C) | Thermistor Resistance (R) | | |
|---------------------|---------------------------|-----------|-----------|
| | Min .(KΩ) | Typ. (KΩ) | Max. (KΩ) |
| -40.0 | 717 | 843 | 989 |
| -35.0 | 535 | 623 | 723 |
| -30.0 | 405 | 466 | 535 |
| -25.0 | 308 | 352 | 400 |
| -20.0 | 238 | 269 | 303 |
| -15.0 | 185 | 208 | 232 |
| -10.0 | 145 | 161 | 178 |
| -5.0 | 113 | 124 | 137 |
| 0.0 | 88.7 | 96.8 | 105 |
| 5.0 | 69.9 | 75.7 | 81.7 |
| 10.0 | 55.4 | 59.5 | 63.8 |
| 15.0 | 44.1 | 47.1 | 50.1 |
| 20.0 | 35.4 | 37.5 | 39.6 |
| 25.0 | 28.5 | 30.0 | 31.5 |
| 30.0 | 22.8 | 24.2 | 25.5 |
| 35.0 | 18.3 | 19.6 | 20.8 |
| 40.0 | 14.9 | 15.9 | 17.1 |
| 45.0 | 12.1 | 13.1 | 14.1 |
| 50.0 | 9.92 | 10.8 | 11.7 |
| 55.0 | 8.16 | 8.91 | 9.7 |
| 60.0 | 6.76 | 7.41 | 8.12 |
| 65.0 | 5.62 | 6.2 | 6.83 |
| 70.0 | 4.7 | 5.21 | 5.77 |
| 75.0 | 3.95 | 4.4 | 4.9 |
| 80.0 | 3.34 | 3.74 | 4.18 |

Table 2 C-MOS Driver IC

Table 2.1 Electrical characteristics for driver IC.

Absolute maximum ratings for driver ICs.

| Parameter | Symbol | Test conditions | Ratings | Unit |
|-------------------------|----------|-----------------|------------------|------|
| Supply voltage | V_{dd} | Surge | 0 ~ 6.5 | V |
| | V_H | Surge | 0 ~ 28 | V |
| Input voltage for logic | V_{IN} | | 0 ~ $V_{dd}+0.5$ | V |

Recommended operating conditions

| Parameter | Symbol | Test conditions | Recommendations | | | Unit |
|-------------------------|-----------|-----------------------|---------------------|------|---------------------|------|
| | | | Min. | Typ. | Max. | |
| Supply voltage | V_{dd} | | 4.5 | 5.0 | 5.5 | V |
| | V_H | Supply voltage for VH | 23.5 | 24.0 | 24.5 | V |
| Input voltage for logic | V_{IH} | (Note 1) | $0.7 \times V_{dd}$ | | V_{dd} | V |
| | V_{IL} | | | | $0.3 \times V_{dd}$ | V |
| Clock frequency | f_{CLK} | cascade | | | 5 | MHz |

(Note 1) Recommended driver IC is 74HC244 or equivalent.

Table 2.2 Electrical characteristics for driver IC.

| Parameter | Symbol | Test conditions | Ratings | | | Unit |
|-------------------------------|---------------------|--|---------|------|------|-------------|
| | | | Min. | Typ. | Max. | |
| Input current | \overline{LATCH} | (Note 1) $V_{dd}=5V$ $V_{IH}=5V$ | | | 3.5 | μA |
| | \overline{STROBE} | | | | 1.5 | μA |
| | CLOCK | | | | 3.5 | μA |
| | DATA IN | | | | 0.5 | μA |
| | \overline{LATCH} | I_{IL} $V_{dd}=5V$ $V_{IL}=0V$ | -3.5 | | | μA |
| | \overline{STROBE} | | -165 | | | μA |
| | CLOCK | | -3.5 | | | μA |
| | DATA IN | | -0.5 | | | μA |
| “L” Output voltage of drivers | V_{OL} | $I_{OL}=30mA$ | | 0.7 | 1.5 | V |
| Leak current of drivers | I_{LEAK} | $V_{OH}=28V$ | | | 1.0 | $\mu A/dot$ |
| Logic supply current | I_{dd} | $SI=1/2f_{CLK}$ $f_{CLK}=5MHz$ | | 11.2 | 35 | mA |

(Note 1) Each \overline{STROBE} includes pull-up resistance of $300K\Omega \pm 50\%$ per IC.

Table 2.3 Switching characteristics for driver ICs.

| Parameter | Symbol | Test conditions | Ratings | | | Unit |
|---------------------------------------|-----------|-----------------|---------|------|------|---------|
| | | | Min. | Typ. | Max. | |
| Clock frequency | f_{MAX} | cascade | | | 5 | MHz |
| Clock pulse width | $tw(T)$ | | 70 | | | ns |
| Data setup time | $tsu(D)$ | | 40 | | | ns |
| Data hold time | $th(D)$ | | 40 | | | ns |
| Latch setup time | $tsu(LA)$ | | 100 | | | ns |
| Latch pulse width | $tw(LA)$ | | 100 | | | ns |
| Strobe to driver Output delay time | $td(DO)$ | | | | 10.5 | μs |

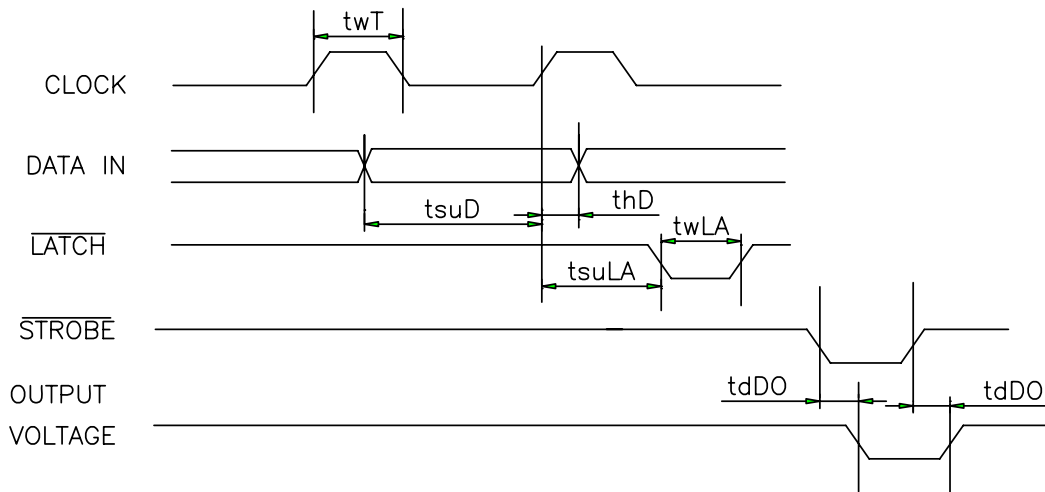

Fig. 2 Thermal Print Head (CH56) Timing Chart

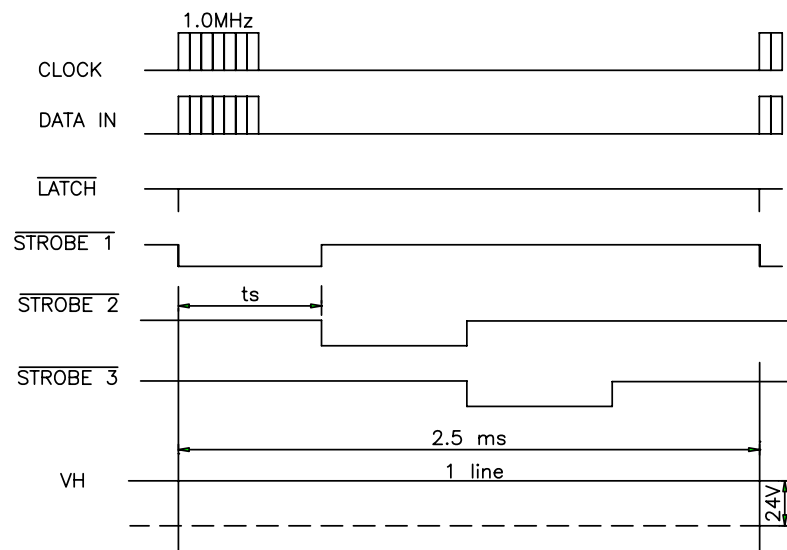

Fig. 3 Schematic Diagram

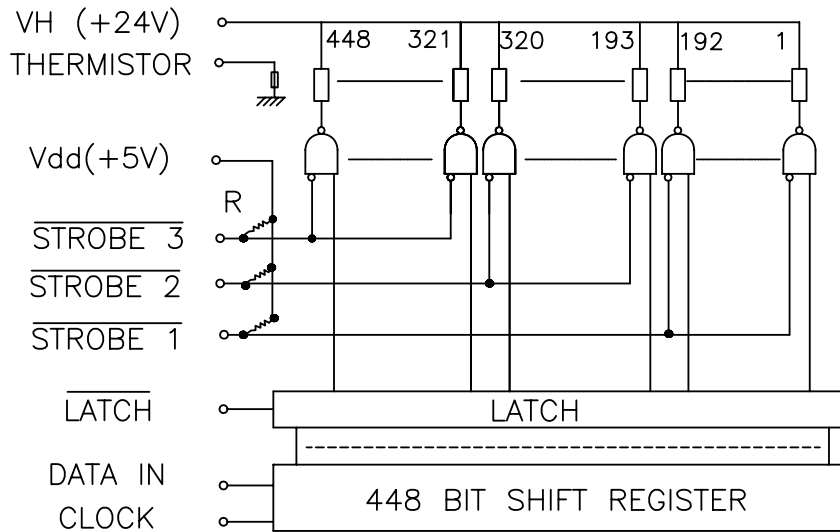

Fig. 4 Cross Section

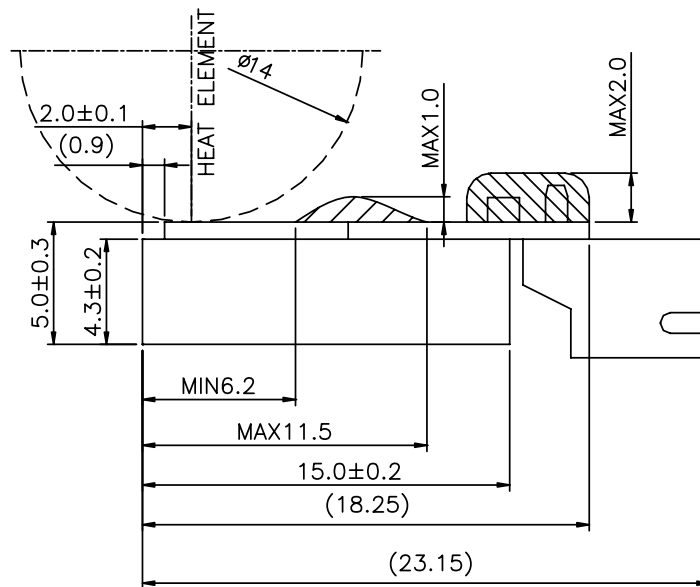

Table. 3 Pin assignment

Connector : S15B-PH-K-S-2.2(LF)(SN):JST or EQUIVALENT

| PIN | NAME | PIN | NAME |
|-----|------------|-----|----------------------|
| 1 | VH | 9 | $\overline{STROBE1}$ |
| 2 | VH | 10 | $\overline{STROBE2}$ |
| 3 | VH | 11 | $\overline{STROBE3}$ |
| 4 | GND | 12 | NC |
| 5 | GND | 13 | CLOCK |
| 6 | GND | 14 | \overline{LATCH} |
| 7 | Vdd | 15 | DATA IN |
| 8 | THERMISTOR | | |

Fig. 5 Dimension

