

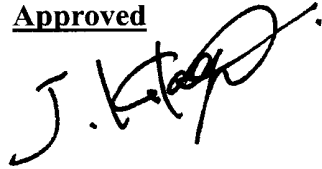

THERMAL PRINT HEAD

K80-9791

SHEC SHANDONG HUALING ELECTRONICS CO., LTD.

#159, Torch Road, Hi-Tech. IDZ
Weihai Shandong, China
Tel: 86-631-5684114
Fax: 86-631-5685493
E-mail: SALES@SHECL.CN

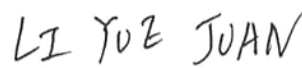
REVISION					<u>Approved</u>
Rev	Description	Date	Approved	Drawn	
A	-----	09-03-31	J.Katagiri	YJ.LI	
					<u>Checked</u> 
					<u>Drawn</u> 

1. Description

This specification is applied to K80-9791 thermal print head.

2. Scope

The K80-9791 is a thermal print head which has heat elements which produce 640 dots with 8 dots/mm by means of a high density thick film process. It also includes C-MOS ICs; Which operate as 640 bits shift-registers, latches and switching transistors to drive heat elements.

3. Outline

Item	Specification	Note
Dimension	Fig.5	
Schematic diagram	Fig.3	
Pin assignment	Table.3	
Print width	80 mm	
Number of heaters	640 dots	
Heater resolution	8 dots/mm	
Heater pitch	0.125 mm	
Printed dot dimension	0.11mm×0.13 mm	Nominal
Heater resistance	$\bar{R}=300\Omega \pm 5\%$	
Specifications for driver ICs	Table.2	
Number of driver ICs	64bits ×10	
Number of data inputs	2 serial input	
Number of strobes	2	
Logic power supply	5 V × 50 mA	at 5 MHz
Specification for Thermistor	$R_{25}=30K\Omega \pm 5\%, B=3,950K \pm 3\%$	Table. 1

4. Maximum ratings

Parameter	Symbol	Specification	Note
Heater energy consumption	Eomax	0.24 mJ/dot	1.25 ms/line
Head voltage	VH	15.2 V	
Logic voltage	Vdd	Vdd=+3V~+5.5V	
Environment temperature	Ta	+5 ° C ~ +50 ° C	Operating
		- 40 ° C ~ +80 ° C	Non-operating
Environment humidity		10 ~ 90%RH	Non-condensing
Maximum operating temperature	Ts	65 ° C 30min. MAX	
		Detected temperature of Thermistor shall not exceed 65 ° C.	Head temperature shall not exceed 70 ° C.

5. Standard printing conditions

Parameter	Symbol	Recommended operating conditions	Note
Speed		1.25 ms/line	
		4 inch/sec	
Heater power consumption	Po	0.36 W/dot	$\bar{R} = 300\Omega$
Heat voltage	VH	12 V	Connectors
Heater energy consumption	Eo (ts)	5°C 0.22mJ/dot (0.61 ms)	$\bar{R} = 300\Omega$ (Note 1)
		25°C 0.19mJ/dot (0.53 ms)	
		40°C 0.17mJ/dot (0.48 ms)	
Supply current	Io	34.5 mA/dot	$\bar{R} = 300\Omega$
Timing chart		Fig. 2	
Platen pressure		10.8 ~ 14.7 N / TPH	
Platen hardness		30~40deg	
Platen diameter		Φ14 Max.	
Scanning resolution		8 line/mm	
Thermal paper		F230AA MITSUBISHI PAPER MILL CO., LTD.	
Optical density		1.1 OD Min.	(Note 2)

(Note 1) Supply energy is defined by the following formula.

$$E_o = I_o^2 \bar{R} t_s = \frac{(VH - V_{com})^2 \cdot \bar{R} \cdot t_s}{(\bar{R} + R_{ic})^2}$$

- $R_{ic} = 33\Omega$: Driver IC "ON" resistance
- t_s : Strobe printing pulse width
- VH : Heat voltage
- \bar{R} : Heater average resistance
- $V_{com} = 0.5V$: Common electrode voltage drop

(Note 2) Printed optical density is measured at 10mm intervals after the starting point. Printed optical density is measured by a RD-914 reflector optical density meter or equivalent .

6. Life expectancy

6.1 The life expectancy under 12.5% printing duty of less at 25° C is defined by the following whichever earlier comes.

Item	Specification	Note
Number of pulses	1×10^8 pulses	
Run length	100 Km	

7. Warning during use

7.1 Strobe signal

During head power supply ON/OFF sequence strobes should be kept "disable".

7.2 Stability of IC operation

Care should be taken for stable operation of driver ICs as indicated bellow. (Fig.1)

(1) If the voltage including surge exceeds maximum rating of driver IC, the TPH may burn out by latch-up. Care should be taken especially when head current changes by strobes or at the ON/OFF sequence. The voltage shall be kept within the following voltage.

VH : 0V ~ +15.2V

Vdd : 0V ~ +6.5V

Other signals : GND -0V ~ Vdd+0.3V

7.3 The heater and driver ICs are electrostatically sensitive. Care should be taken not to touch connectors with hands or an electrostatically charged object. It is recommended that brushes near the head be provided to discharge electrostatic build up.

7.4 On the surface near the heater, do not apply any hard material. The abrasion resistant layer is fragile to mechanical impact.

7.5 Ink dregs adhered to the heater should be wiped off softly with a soft cloth dipped alcohol or detergent. Do not use sandpaper or equivalent.

7.6 Keep hard particles out of the heater surface. Hard particles may scratch the abrasion resistant layer.

7.7 The average print duty should be less than 25%.

7.8 When the printer is on standby, the thermal head (VH) must be switched off.

Fig. 1 Recommend Connection

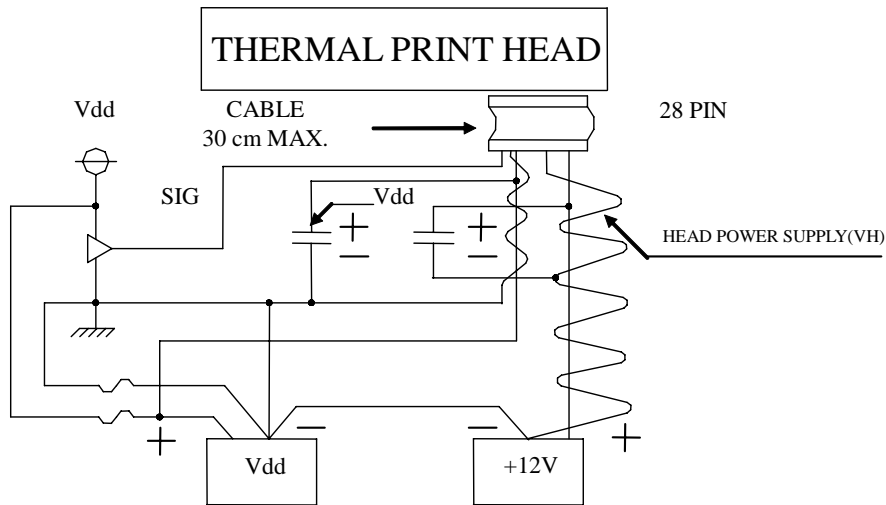

Table. 1 Thermistor

$$R_{25} = 30K\Omega \pm 5\%, B_{CONST} = 3950\text{kelvin} \pm 3\%, R = R_{25}e^{B(1/T - 1/T_{25})}$$

Temperature (° C)	Thermistor Resistance (R)		
	Min .(KΩ)	Typ. (KΩ)	Max. (KΩ)
-40.0	717	843	989
-35.0	535	623	723
-30.0	405	466	535
-25.0	308	352	400
-20.0	238	269	303
-15.0	185	208	232
-10.0	145	161	178
-5.0	113	124	137
0.0	88.7	96.8	105
5.0	69.9	75.7	81.7
10.0	55.4	59.5	63.8
15.0	44.1	47.1	50.1
20.0	35.4	37.5	39.6
25.0	28.5	30.0	31.5
30.0	22.8	24.2	25.5
35.0	18.3	19.6	20.8
40.0	14.9	15.9	17.1
45.0	12.1	13.1	14.1
50.0	9.92	10.8	11.7
55.0	8.16	8.91	9.7
60.0	6.76	7.41	8.12
65.0	5.62	6.2	6.83
70.0	4.7	5.21	5.77
75.0	3.95	4.4	4.9
80.0	3.34	3.74	4.18

Table. 2 C-MOS Driver IC

Table 2.1 Electrical characteristics for driver IC.

Absolute maximum ratings for driver ICs.

Parameter	Symbol	Test conditions	Ratings	Unit
Supply voltage	V_{dd}	Surge	0 ~ 6.5	V
	VH	Surge	0 ~ 15.2	V
Input voltage for logic	V_{IN}		0 ~ $V_{dd} + 0.5$	V

Recommended operating conditions

Parameter	Symbol	Test conditions	Recommendations			Unit
			Min.	Typ.	Max.	
Supply voltage	V_{dd}		3.0	3.3	5.5	V
	VH	Supply voltage for VH	-	12	15.2	V
Input voltage for logic	V_{IH}	(Note 1)	$0.7 \times V_{dd}$		V_{dd}	V
	V_{IL}				$0.3 \times V_{dd}$	V
Clock frequency	f_{CLK}	cascade			5	MHz

Table 2.2 Electrical characteristics for driver IC.

Parameter	Symbol	Test conditions	Ratings			Unit
			Min.	Typ.	Max.	
Input current	\overline{LATCH}	(Note 1) $V_{dd} = 5V$ $V_{IH} = 5V$			5.0	μA
	STROBE				275	μA
	CLOCK				5.0	μA
	DATA IN				0.5	μA
	\overline{LATCH}	$V_{dd} = 5V$ $V_{IL} = 0V$	-5.0			μA
	STROBE		-1.5			μA
	CLOCK		-5.0			μA
	DATA IN		-0.5			μA
“L”Output voltage of drivers	V_{OL}	$I_{OL} = 30mA$		0.7	1.5	V
Leak current of drivers	I_{LEAK}	$V_{OH} = 28V$			1.0	$\mu A/dot$
Logic supply current	I_{dd}	$SI = 1/2 f_{CLK}$ $f_{CLK} = 5MHz$		16	50	mA
“H”Level output	V_{OH}	So, no load	4.45			V
	I_{OH}	So, $V_{OH} = V_{dd} - 0.4V$			-0.5	mA
“L”Level output	V_{OL}	So, no load			0.05	V
	I_{OL}	So, $V_{OL} = 0.4V$	0.5			mA

(Note 1) Each STROBE includes pull- down resistance of $300K\Omega \pm 50\%$ per IC

Table 2.3 Switching characteristics for driver ICs.

Parameter	Symbol	Test conditions	Ratings			Unit
			Min.	Typ.	Max.	
Clock frequency	f_{MAX}	cascade			5.0	MHz
Clock pulse width	$tw(T)$		70			ns
Data setup time	$tsu(D)$		40			ns
Data hold time	$th(D)$		40			ns
Latch setup time	$tsu(LA)$		100			ns
Latch pulse width	$tw(LA)$		100			ns
Clock to So delay time	$tds(O)$				120	ns
Strobe to driver Output delay time	$td(DO)$				18.0	μs

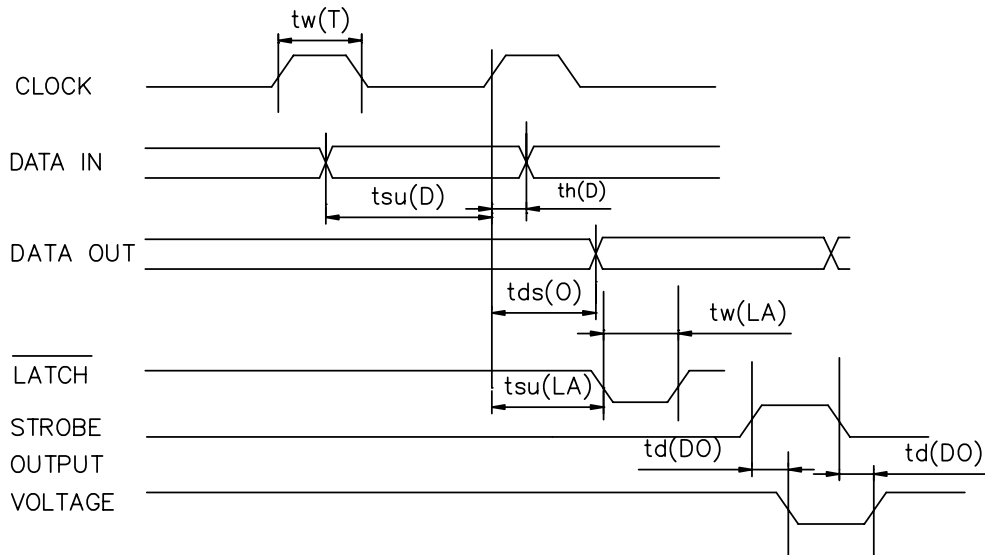

Fig. 2 Thermal Print Head (K80-9791) Timing Chart

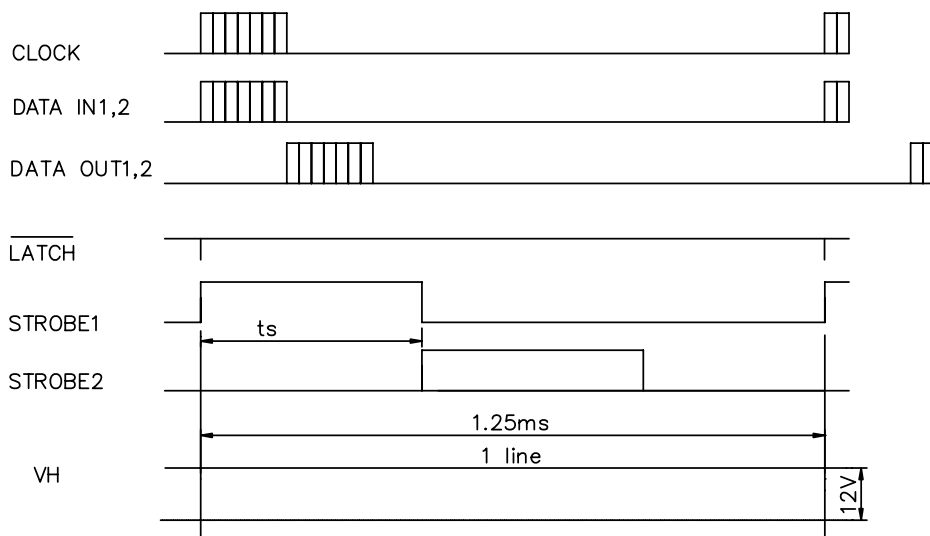

Fig. 3 Schematic Diagram

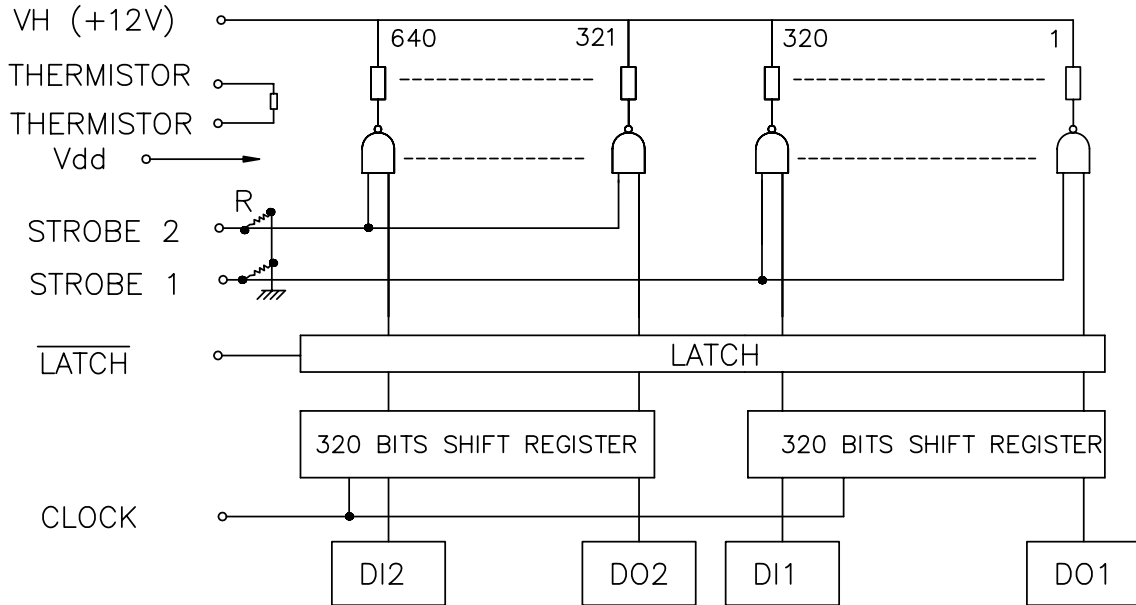

Fig. 4 Cross Section

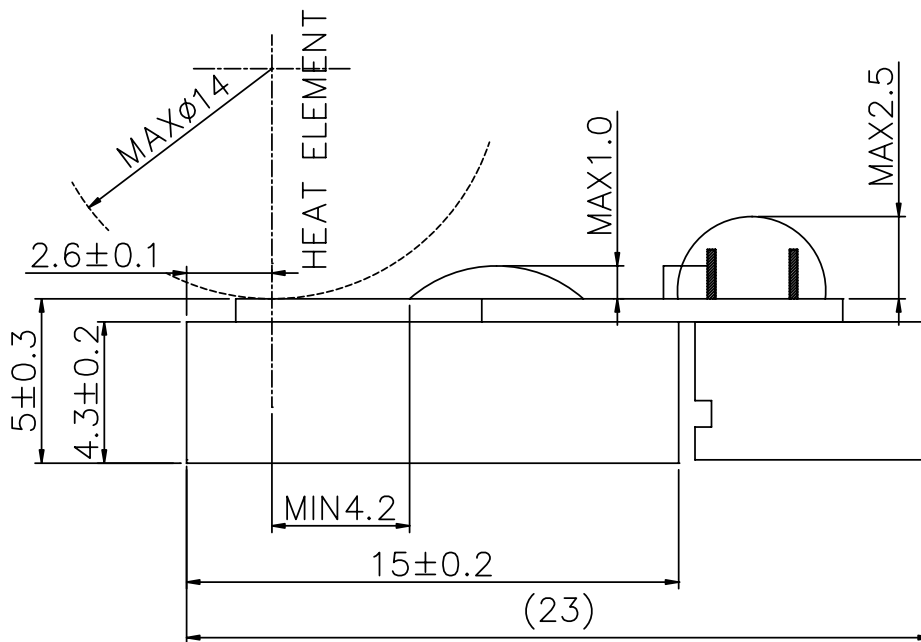

Table. 3 Pin assignment

Connector : IMSA-9604S-28F or EQUIVALENT

PIN	NAME	PIN	NAME	PIN	NAME	PIN	NAME
1	VH	8	GND	15	VDD	22	GND
2	VH	9	GND	16	THERMISTOR	23	DATAOUT2
3	VH	10	GND	17	THERMISTOR	24	DATAIN2
4	VH	11	GND	18	STROBE2	25	VH
5	DATA OUT1	12	STROBE1	19	GND	26	VH
6	DATA IN1	13	CLOCK	20	GND	27	VH
7	GND	14	<i>LATCH</i>	21	GND	28	VH

Fig. 5 Dimension

